



March 16th Activity

Driving tour over the mountains to Dahlonega. See page 3.

FUTURE PLANS OF JAGUAR

The December 2002 issue of CAR (published in the U.K.) and the January 2003 issue of Automobile Magazine both included some interesting information about the future plans at Jaguar Cars. Both articles essentially made the same points with one exception noted below. Some of the more interesting points are as follows:

1. The F-type roadster is again in Jaguar's future plans for 2007 according to CAR. Automobile magazine doesn't refer to the F-type but does make references to an X-type roadster. It appears that both magazines are talking about the same car but using different names. CAR does make the point that plans for the F-type as a "radical" roadster have been canned. I assume they were referring to the plans to produce the F-type as a mid-engined car similar to the Porsche Boxster.
2. Jaguar will abandon platform sharing with Ford and other brands within the Ford stable. Instead, they will try to use a base platform for both the X-type and the S-type. The X-type would become a strictly rear wheel drive car.
3. All body structures would be designed to accommodate a wide range of engines, including V-6s, V-8s, and V-10s.
4. Jaguar intends to have three "halo" cars – an X-type coupe, an S-type coupe, and the F-type roadster or X-type roadster.
5. Future design direction will include oval type grilles for sports cars (as per the E-type and XK8), the four lamp front ends for sedans (like the current XJ and X-type), and the coupes will feature a "shield" grille framed by unequal sized round headlamps (such as that found on the 2001 R-Coupe concept car).

The articles also suggested that a new S-type coupe could be produced as early as 2005. It will be interesting to see how much of this actually happens. It certainly sounds encouraging for the future of Jaguar.



PRESIDENT'S COLUMN

It is good to see the start of a new driving season. I had the convertible top down several times over the past couple of weeks. I believe I even saw our friendly newsletter editor out and about with his back window unzipped. When cars comprise as important a part of your life as they do for us, you are always waiting for a chance to drive them. Don't get me wrong; everyone that knows me is aware of the fact that I will drive an old Jag around in any kind of weather, but it is so much nicer to go out and just cruise when the weather is nice.

We will be having several great driving events again this year. In fact, our March event will be a tour over the mountains to Dahlonega. I won't tell you our exact route here but it is very scenic and is probably a route that most of you have not ever taken. Our own Chris Padgett has done a great job of planning for this event. I hope that we will be seeing you at most of our events. I know you will enjoy them. I would also like to encourage you to do as Chris has done and plan an event. It does not take that much time to do it and it is very rewarding to know that you have helped others in the pursuit of their automotive enjoyment. It also provides diverse activities for all of us. If the same people plan all the events then we could end up doing the same old things over and over. When different people plan each event we get a chance to try out something new.

Happy Motoring
Terry



**Dreamin'
of summer**
*Rich Mountain Road
Cherry Log, GA*

MEMBERSHIP AND FINANCE STATUS REPORT

The Club begins 2003 with 37 of the 47 members at the end of 2002. We added eight members at the end of 2002 whose memberships were to become effective at the beginning of 2003. Thus, our total membership as of January 1, 2003 is 45. As in the past, we have prospects to whom we have provided information. This is a very good position for a club that is only beginning its second year.

The Club treasury has approximately \$1,200 on hand and should increase by another \$300 when all advertising revenue is collected.

As we strengthen our finances, we should be able to take some risks on some types of events that might require an up front expenditure.

A detailed financial report for 2002 has been provided to the Board of Directors and any member who would like to obtain a copy should call or e-mail Roy Cleveland.



KIRKMAN WINNER OF REGIONAL JCNA AWARD

Congratulations to Dave Kirkman for having the highest scoring (99.84) E-Type in JCNA concours competition for Class 06 (Series 2) in the Southeastern U.S. for 2002. We look forward to seeing Dave's beautiful Willow Green E-Type at some of our events this year.



The Club-Friendly Jaguar Parts & Accessory Store



384 page Vol. XII,
Jaguar Parts Catalog



80 page Vol. I, Jaguar Performance
& Accessory Collection

- Knowledgeable, Helpful Staff
 - World-Class Catalogs
 - JCNA Member Discount
 - Deep Coverage For All Post-War Jaguars
 - Same-Day Shipping*
- Proud supporters of JCNA and local club activities**

* XKs' normal policy is to fill and ship orders received before 2:00 pm, Pacific time, the same-day. Unforeseen circumstances may cause delays, next-day shipping may result in some cases.



Full color Arden® brochures for
XK8, XJ8, S-TYPE AND X-TYPE

You've Seen The Rest, Now Get The Best ... By using the XKs Unlimited library of catalogs you'll have access to nearly 500 pages showing thousands of parts and accessories for all post-war Jaguars, from the XK Series right up to the new X-TYPE. This valuable resource is yours for the asking! We are pleased to provide any and all of our catalogs to club members at absolutely no charge. Call, fax or go on-line today to order our current literature.



... It's In The Details

XKs UNLIMITED, INC.

850 Fiero Lane, San Luis Obispo, CA, 93401
Order Line: (800) 444-5247 FAX: (805) 544-1664
web: www.xks.com • e-mail: xksunltd@aol.com

— SINCE 1973 —

CUNNINGHAM APPOINTED JCNA REGIONAL DIRECTOR

Lynn Cunningham, an NGJC member, was recently appointed as a regional director of JCNA from the Southeast. Prior to moving to Atlanta, Lynn was instrumental in founding the JCNA affiliated club in Nashville, Tennessee. We are fortunate to have a member from our club in this important position within the national club. The appointment reflects JCNA President Gary Hagopian's confidence in Lynn. It may somewhat reflect JCNA's expectations for our club.

If you have suggestions regarding JCNA, please communicate them to Lynn. His home number is 770-512-8707.



CALENDAR AND SCHEDULE OF EVENTS FOR 2003

February 15 -

Tech session at Hyundai Training Center on automotive fluids, oils, etc.

March 16 -

Driving tour in North Georgia

April 19 -

Tour of Athens, visit to G. Bugg car collection, lunch & Ga Botanical Garden

May 18 -

British Motor Car Day May- Possibly a one day driving tour in North Georgia

June 28 -

Overnight driving tour

July 19 -

Tour of the Panoz car factory

August 16 -

Tech session

Aug. or Sept. -

Training session for judges for JCNA Concours

September 20-

JCNA sanctioned Concours at Chattahoochee Country Club in Gainesville

October 11 -

Fall Leaf Cruise in North Georgia

18 -

EURO 2003 Auto Festival at BMW manufacturing plant

November-

Southern British Weekend in Chattanooga

15 -

Business Meeting in the Atlanta area - location to be announced

December 15 -

Christmas Party at the Vinings Club



THE WORLD'S LARGEST INDEPENDENT JAGUAR SPARES SPECIALISTS
BRIDGNORTH UK - MANCHESTER USA - MACON FRANCE - OOSTERWIJK HOLLAND

Need spares for your Jaguar?

Your treasured British Jaguar classic...



...deserves the best in Stateside service!



Free 300 page catalogue available by request.
Experienced, knowledgeable, friendly staff.
Fast interstate mail order service.
Tax free spares shopping in New Hampshire.
Spares available for all popular Jaguar models

SNG BARRATT USA, 92 LONDONDERRY TURNPIKE, MANCHESTER, NH 03104 USA.
TEL +1 603 622 1050 FAX +1 603 622 0049
E-MAIL SALES.USA@SNGBARRATT.COM WEBSITE WWW.SNGBARRATT.COM

MARCH ACTIVITY SUNDAY, MARCH 16

Assembly time: 10:00 A.M.

Location: Lee Newton Memorial Park, Jasper, Ga.

Directions: Take I 575/515 North to Ga Hwy 53. Turn east onto Ga. 53. Go approximately one mile. The park with a ride share lot is on the left.

Our March activity will be a driving tour over the mountains to Dahlonega. We will eat at the Smith House. Ample time will be available to browse the many antique shops we will pass. Reservations not necessary, but call Terry if you think you will be meeting us enroute or if you will be late.

OFFICERS

President: Terry Hulsey • 770-971-4904 • hulsey@fulton.k12.ga.us

Vice President: Joe Newell • 706-276-6779 • joe@masseyfair.com

Treasurer: Roy Cleveland • 770-538-0858 • rmcleland@charter.net

Secretary: Dianne Hulsey • 770-971-4904 • jagman1@mindspring.com

Newsletter Production: John C. Yates • 770-516-0296 • johncyates@attbi.com





CHAPTER DISCOUNTS

Hennessy Jaguar is offering a 15% discount on parts and labor to all North Georgia Jaguar Club members. This would include, of course, all accessory and automobilia type items. All you need to do is show your JCNA membership card which has our Club numerical code on it and remind the service advisor or the parts sales person of the discount. If you should have a problem, at the Buckhead location politely ask the person with whom you are dealing to contact Randy Coile, Sales Manager at Hennessy Buckhead, who arranged this discount. If you are at the Gwinnett location and have a problem, ask the person to contact Steve Newcome, Sales Manager at Hennessy Gwinnett.

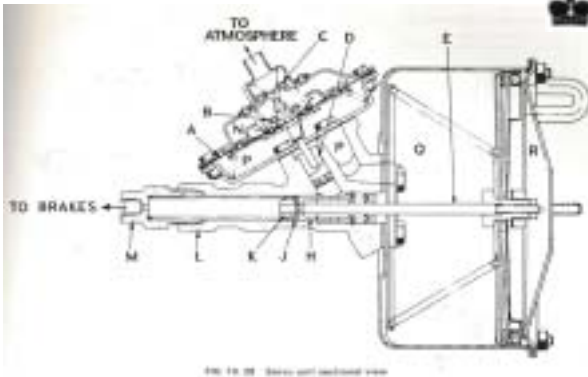

JAGUAR AND CLASSIC AUTOMOBILE CALENDAR OF EVENTS FOR 2003

March 7-9 – Amelia Island Concours

March 12-16 – Atlanta Auto Show

March 21-22 – JCNA AGM in Charlotte

May 1-5 – JCNA Challenge Championship in Phoenix

May 9-11 – XK Register (Jaguar Drivers Club) Spring Weekend in Yorkshire, England

June 11-13 – Goodwood Festival of Speed – Goodwood, England

June 15 – International XK Day (Jaguar Drivers Club) at Brooklands, England

August 17 – Pebble Beach Concours d'Elegance – Pebble Beach, California

September 5-7 – Goodwood Revival – Goodwood, England

October 17-19 – EURO 2003 Auto Festival at BMW manufacturing plant



**HENNESSY
JAGUAR**

**COMING SOON,
The All-New 2004 Jaguar XJ8!**



ATLANTA • Piedmont at East Paces Ferry • 404.261.5700 • www.hennessyjaguar.com



NGJC Soft Sided Coolers

In British Racing Green with Tan Trim and NGJC Logo in White.

\$12.50

Plus Shipping
or
pick one up
at the
next club
event!



Treasure Chest Design features
a stay dry area in the top.



Contact: Roy Cleveland
770-538-0858 or Email: rmcleveland@charter.net

Classified Advertising Rates

NGJC Members,
8 lines, 3 mos., FREE
Non-Members,
8 lines, 1 mo., \$10

Commercial Advertising Rates

Per Quarter
Full Page \$200
1/2 Page \$110
1/4 Page \$60
Business Card \$30
Call for frequency discounts



P.O. Box 1377
Gainesville, GA 30503



770-538-0858
FAX: 770-538-0858
Email:
rmcleveland@charter.net



Affiliated with Jaguar Clubs of North America